

GENERAL ENGINEERING SCIENCE I

Attempt ALL questions

Marks for each question are shown in brackets

1. A man rows a boat 2.6 km downstream in 12 minutes and 2.6 km upstream in 19 minutes.

Calculate EACH of the following:

- (a) the boat speed in still water in m/s; (5)
(b) the speed of the current in m/s. (3)

2. The total surface area of a solid cylinder is given by the following formula:

$$s = 2\pi r^2 + 2\pi rh \quad \text{where } h = \text{height} \quad r = \text{radius}$$

- (a) Express h in terms of the other quantities. (3)
(b) Calculate the height to the nearest centimetre of a cylinder having a diameter of 8cm and a total surface area of 327cm^2 . (5)

3. With reference to lifting machines:

- (a) define EACH of the following:
(i) force ratio (mechanical advantage); (1)
(ii) movement ratio (velocity ratio); (1)
(b) define efficiency in terms of force ratio and movement ratio; (1)
(c) a machine has an efficiency of 47% when lifting a load of 2.03 tonne.

Calculate the effort required to lift the 2.03 tonne load given that the movement ratio for this machine is 210. (5)

4. A vertical steel bar is supporting an axial load of 3.5 tonne. Under these conditions the bar, which is 440 mm in length, is compressed by 0.24 mm.

Calculate the diameter of the bar given that the modulus of elasticity for the material

$$(E) = 200 \text{ GN/m}^2. \quad (10)$$

5. Fig Q5 shows a uniform simply supported beam AB.

The beam has a mass of 625kg and supports a point load of 95kg such that reaction $R_A = 3.6\text{kN}$

Calculate EACH of the following:

(a) the value of the reaction R_B ; (3)

(b) the position of the 95kg load. (5)

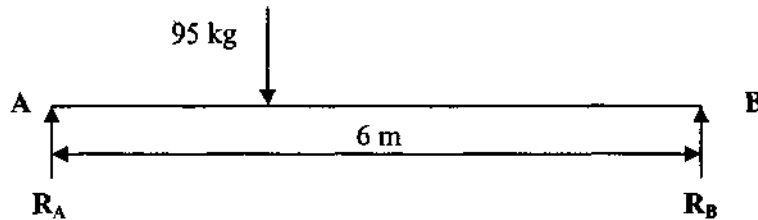

Fig Q5

6. An electric motor comes to rest from running speed in 2 minutes 24 seconds and turns through 1782 revolutions whilst slowing down.

Calculate EACH of the following:

(a) the running speed in rev/min; (4)

(b) the retardation in rad/s^2 . (4)

7. Calculate the immersed depth, to the nearest metre, when a pressure gauge fitted in a submersible vessel indicates 5 bar in water of density 1018kg/m^3 . (8)

8. A drydock gate has a width to depth ratio of 3:1. When flooded to the top on one side only with water of density 1016kg/m^3 the hydrostatic force on the gate is 14.95MN.

Calculate EACH of the following:

(a) the depth of the gate; (6)

(b) the width of the gate. (2)

9. A box barge, 15 metres long and 6 metres beam, has a displacement of 459 tonne when floating in river water of 1020kg/m^3 . The barge remains in the river and is now loaded with fresh water and floats at a draught of 7.94 metre.

Calculate for EACH of the following:

- (a) the original draught; (4)
- (b) the mass of fresh water loaded. (4)

10. A solid hemisphere has a diameter of 18cm.

Calculate EACH of the following:

- (a) the volume of the hemisphere; (4)
- (b) the *total* surface area in m^2 . (6)

11. A vessel has a displacement of 2060 tonne and a KG of 4.6m.

Calculate the value of KM given that a mass of 6 tonne, already on board, when moved 4 metres across the deck causes the vessel to heel by 0.95°

Given $m \times d = \Delta GM \tan \theta$ (8)

12. Fig Q12 shows a simple wall crane.

Calculate EACH of the following:

(a) the length of the tie; (3)

(b) the force in the tie when supporting a 1.5 tonne load. (5)

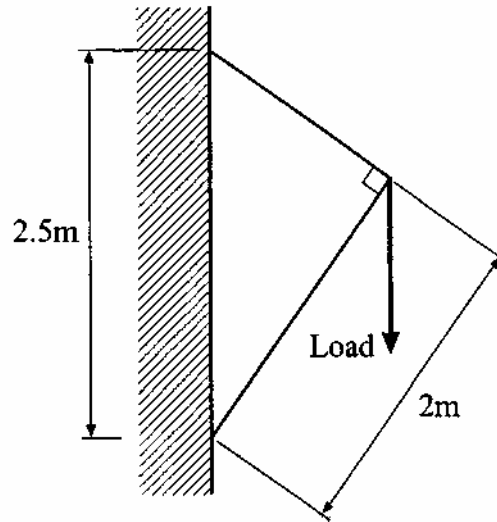

Fig Q12